

WIRE TO PCB TYPE TERMINAL BLOCK – ETBT14-□□0S SERIES



WIRE TO WIRE TYPE

PITCH=11mm

■ FEATURES

- Can be supplied in any number of positions
- Special terminal protector design to ensure reliable terminal fixed
- UL 94V-0 grade fire retardant engineering plastic
- Be capable of clamping a wide range of wire diameters
- Wide choice of Terminal & Protective Cover

■ SPECIFICATIONS

- Pitch 11mm
- Wire range 10~18 AWG
- Rating 30 Amp, 300 VAC
- Housing PBT(UL94V-0)Black
- Terminals Nickel plated over Copper Alloy
- Screws M4.0x0.7P,Zinc plated over Steel
- Torque 1.2N-m(10.6 lb-in) Max
(tested by manual torque screwdriver)
- Operating temperature -40°C~+140°C
(includes temperature rise limit)
- UL pending 30 Amp,300 VAC
- TUV pending 32 Amp,4mm²,450 VAC



■ PART NUMBERING SYSTEM

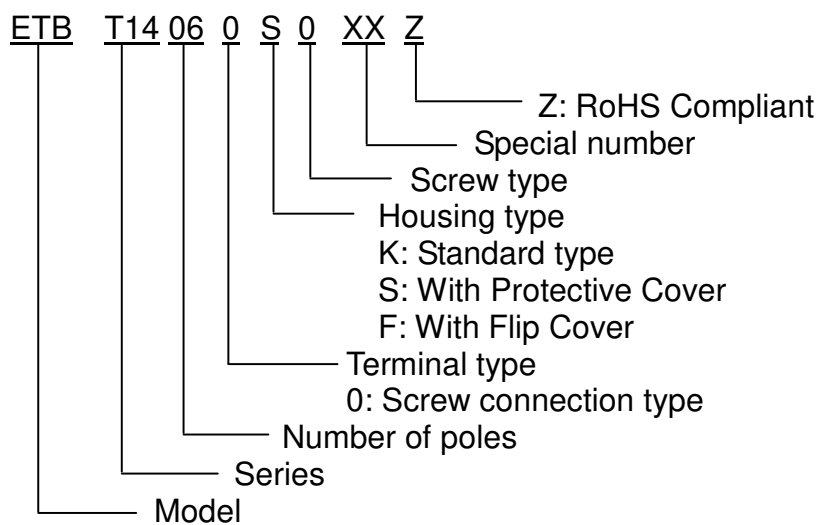

WIRE TO PCB TYPE TERMINAL BLOCK – ETBT14-□□0S SERIES



■ DRAWING

ETBT140X0K000Z

Pitch=11.0mm

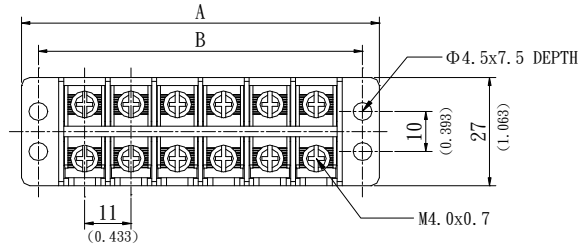

ETBT140X0S000Z

Pitch=11.0mm

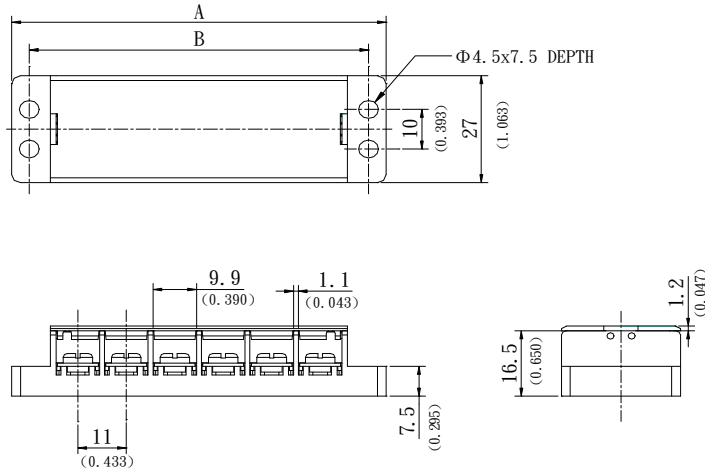

POLE DIM.	2	3	4	5	6	7	8	9
A	41 (1.615)	52 (2.048)	63 (2.482)	74 (2.915)	85 (3.348)	96 (3.781)	107 (4.214)	118 (4.647)
B	33 (1.300)	44 (1.733)	55 (2.166)	66 (2.599)	77 (3.032)	88 (3.465)	99 (3.898)	110 (4.331)