

# SLIM SMD INDUCTOR – ESD5D12 SERIES



## ●FEATURE

1. Low profile and small size(Height=1.20MAX)
2. Low DC resistance
3. Magnetic Shielding type

## ●Applications

1. LCD panels
2. Digital camera, others portable

## ●Shape and Dimension

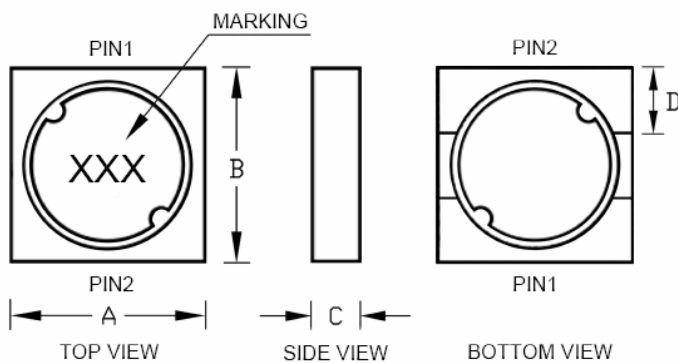

## ●Schematics and Land Patterns(mm)

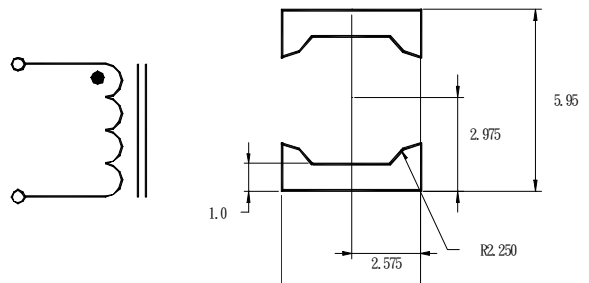

A=5.30m/m MAX ; B=5.30m/m MAX ; C=1.20m/m MAX ; D=2.00m/m REF. ; MARKING= Inductance value

## ●Specification

Part Number	L (uH)	Marking	DCR (ΩTyp.)	Isat (A)	Irms (A)
ESD5D12-R47M	0.47±20%	R47	0.0246	3.86	3.19
ESD5D12-1R2M	1.20±20%	1R2	0.0366	2.45	2.62
ESD5D12-1R5M	1.50±20%	1R5	0.0521	2.08	2.19
ESD5D12-2R2M	2.20±20%	2R2	0.0747	1.80	1.83
ESD5D12-3R3M	3.30±20%	3R3	0.1043	1.42	1.55
ESD5D12-4R7M	4.70±20%	4R7	0.1177	1.29	1.46
ESD5D12-6R2M	6.20±20%	6R2	0.1699	1.08	1.21
ESD5D12-8R2M	8.20±20%	8R2	0.2399	0.931	1.02
ESD5D12-100M	10±20%	100	0.2844	0.818	0.938
ESD5D12-150M	15±20%	150	0.4089	0.692	0.782
ESD5D12-220M	22±20%	220	0.6338	0.574	0.628
ESD5D12-330M	33±20%	330	0.9289	0.474	0.519
ESD5D12-470M	47±20%	470	1.37	0.391	0.428
ESD5D12-680M	68±20%	680	2.16	0.325	0.341
ESD5D12-820M	82±20%	820	2.36	0.297	0.326
ESD5D12-101M	100±20%	101	2.64	0.273	0.308

## SLIM SMD INDUCTOR – ESD5D12 SERIES



Part Number	L ( $\mu\text{H}$ )	Marking	DCR ( $\Omega$ Typ.)	Isat (A)	Irms (A)
ESD5D12-151M	150 $\pm$ 20%	151	3.96	0.220	0.251
ESD5D12-221M	220 $\pm$ 20%	221	4.76	0.181	0.229
ESD5D12-331M	330 $\pm$ 20%	331	7.25	0.148	0.186
ESD5D12-471M	470 $\pm$ 20%	471	8.95	0.126	0.167
ESD5D12-681M	680 $\pm$ 20%	681	11.30	0.104	0.149
ESD5D12-821M	820 $\pm$ 20%	821	14.93	0.095	0.129
ESD5D12-102M	1000 $\pm$ 20%	102	17.20	0.086	0.121

Note1. Measurement frequency of Inductance value : at 100KHz, 0.25V

Note2. Measurement ambient temperature of L, DCR and IDC : at 25°C

Note3. IDC : This indicates the value of current when the inductances is 20% lower than its initial value at D.C. superimposition or D.C. current when at  $\Delta t=40^\circ\text{C}$ , which is lower. ( $T_a=20^\circ\text{C}$ )

Note4. Packaging: Taping ; Quantity: 1000 Piece/reel



## GENERAL CHARACTERISTICS

1. Operating temperature range: -40 TO + 105°C (Includes temperature when the coil is heated)
2. External appearance: On visual inspection, the coil has no external defects.
3. Terminal strength: After soldering. Between copper plate and terminals of coil. Push in two directions of X.Y withstanding at below conditions.  
Terminal should not peel off. (refer to figure at right) 5. 0N 60 sec.
4. Insulating resistance: Over 100MΩ at 100V D.C. between coil and core.
5. Dielectric strength: No dielectric breakdown at 100V D.C. for 1 minute between coil and core.
6. Temperature characteristics: Inductance coefficient  $(0\sim 2,000)\times 10^{-6}/^{\circ}\text{C}$  (-25~+80°C degree Celsius), inductance deviation within  $\pm 5.0\%$ , after 96 hours.
7. Humidity characteristics (Moisture Resistance): Inductance deviation within  $\pm 5\%$ , after 96 hours in 90~95% relative humidity at  $40 \pm 2^{\circ}\text{C}$  and 1 hour drying under normal condition.
8. Vibration resistance: Inductance deviation within  $\pm 5\%$ , after vibration for 1 hour. In each of three orientations at sweep vibration (10~55~10 Hz) with 1.5mm P-P amplitudes.
9. Shock resistance: Inductance deviation within  $\pm 5\%$ , after being dropped once with 981m/s<sup>2</sup> (100G) shock attitude upon a rubber block method shock testing machine, in three different orientations.
10. Resistance to Soldering Heat: 260°C, 10 seconds (See attached recommend reflow)
11. Storage condition: Temperature Range: 0°C ~ 35°C ; -40°C ~ 105°C (after PCB) , Humidity Range: 50% ~ 70% RH
12. Use components within 12 months. If 12 months or more have elapsed, check solderability before use.
13. Reflow profile recommend:

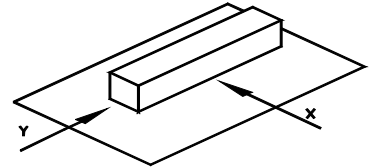

Lead-free heat endurance test

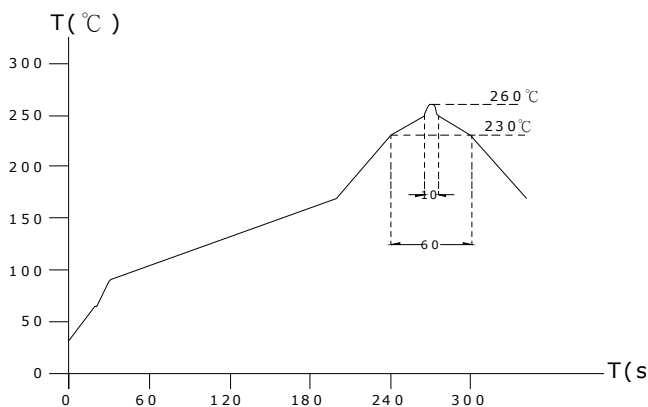

Lead-free the recommended reflow condition

