

SMD POWER INDUCTOR – ETPRH1209 SERIES

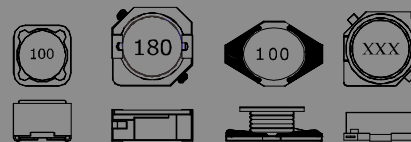

●FEATURE

1. Low core loss for high frequency power application
2. Large terminal surface

●Applications

1. Portable communication equipment, notebook computer
2. Hard Disk drives, and other electronic equipment

●Shape and Dimension

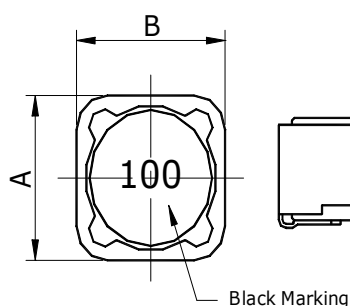

●Schematics and Land Patterns(mm)

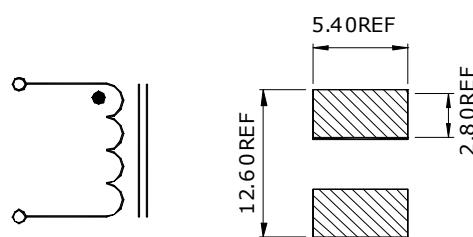

A=12.0±0.30m/m ; B=12.0±0.30m/m ; C=10.00m/m MAX

●Specification

Part Number	L(uH)	STAMP	DCR(ΩMax)	IDC(A) MAX
ETPRH1209-1R5N	1.5±30%	1R5	0.0047	16.00
ETPRH1209-2R4N	2.4±30%	2R4	0.0057	15.00
ETPRH1209-3R3N	3.3±30%	3R3	0.0086	14.00
ETPRH1209-5R0N	5.0±30%	5R0	0.0105	11.00
ETPRH1209-6R8N	6.8±30%	6R8	0.0132	10.00
ETPRH1209-8R2N	8.2±30%	8R2	0.0153	8.20
ETPRH1209-100M	10±20%	100	0.018	7.50
ETPRH1209-120M	12±20%	120	0.019	7.00
ETPRH1209-150M	15±20%	150	0.024	6.00
ETPRH1209-180M	18±20%	180	0.031	5.50
ETPRH1209-220M	22±20%	220	0.039	5.00
ETPRH1209-270M	27±20%	270	0.045	4.50
ETPRH1209-330M	33±20%	330	0.050	4.00
ETPRH1209-390M	39±20%	390	0.059	3.80
ETPRH1209-470M	47±20%	470	0.069	3.50
ETPRH1209-560M	56±20%	560	0.079	3.20
ETPRH1209-680M	68±20%	680	0.088	3.00
ETPRH1209-820M	82±20%	820	0.110	2.60

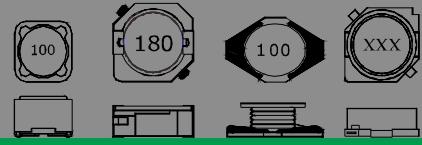

Part Number	L(uH)	STAMP	DCR(ΩMax)	IDC(A) MAX
ETPRH1209-101M	100±20%	101	0.140	2.20
ETPRH1209-121M	120±20%	121	0.160	2.00
ETPRH1209-151M	150±20%	151	0.200	1.80
ETPRH1209-181M	180±20%	181	0.270	1.60
ETPRH1209-221M	220±20%	221	0.300	1.50
ETPRH1209-271M	270±20%	271	0.400	1.30
ETPRH1209-331M	330±20%	331	0.450	1.20
ETPRH1209-391M	390±20%	391	0.550	1.10
ETPRH1209-471M	470±20%	471	0.600	1.00
ETPRH1209-561M	560±20%	561	0.700	0.90
ETPRH1209-681M	680±20%	681	0.840	0.82
ETPRH1209-821M	820±20%	821	1.06	0.80
ETPRH1209-102M	1000±20%	102	1.27	0.76

Note1. Measurement frequency of Inductance value : at 1KHz, 0.25V

Note2. Measurement ambient temperature of L, DCR and IDC : at 25°C

Note3. IDC: the current when the inductance decreases to 75% over of it's nominal value.

Note4. Inductance tolerance: M: ±20%

Note5. Taping: reel ; Quantity: 300pcs/reel

●Order Code(Part Number)

1. TYPE NAME : ETPRH1209
2. INDUCTANCE VALUE : 100(10uH)
3. INDUCTANCE TOLERANCE : M(±20%)

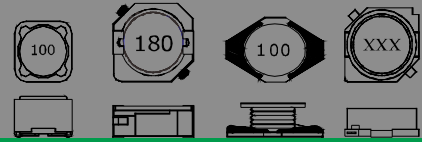

GENERAL CHARACTERISTICS

1. Operating temperature range: -40 TO + 125°C (Includes temperature when the coil is heated)
2. External appearance: On visual inspection, the coil has no external defects.
3. Terminal strength: After soldering. Between copper plate and terminals of coil. Push in two directions of X.Y withstanding at below conditions.
Terminal should not peel off. (refer to figure at right) 5. 0N 60 sec.
4. Insulating resistance: Over 100MΩ at 100V D.C. between coil and core.
5. Dielectric strength: No dielectric breakdown at 100V D.C. for 1 minute between coil and core.
6. Temperature characteristics: Inductance coefficient $(0\sim 2,000)\times 10^{-6}/^{\circ}\text{C}$ (-25~+80°C).
7. Humidity characteristics(Moisture Resistance): Inductance deviation within $\pm 5\%$, after 96 hours in 90~95% relative humidity at $40 \pm 2^{\circ}\text{C}$ and 1 hour drying under normal condition.
8. Vibration resistance: Inductance deviation within $\pm 5\%$, after vibration for 1 hour. In each of three orientations at sweep vibration (10~55~10 Hz) with 1.5mm P-P amplitudes.
9. Shock resistance: Inductance deviation within $\pm 5\%$, after being dropped once with 981m/s² (100G) shock attitude upon a rubber block method shock testing machine, in three different orientations.
10. Resistance to Soldering Heat: 260°C, 10 seconds(See attached recommend reflow)
11. Storage environment: Storage condition: Temperature Range: 10°C ~ 35°C (Generally: 21°C ~ 31°C) , Humidity Range: 50% ~ 80% RH (Generally: 65% ~ 75%) ; Transportation condition: Temperature Range: -35°C ~ 85°C , Humidity Range: 50% ~ 95% RH
12. Use components within 12 months. If 12 months or more have elapsed, check solderability before use.
13. Reflow profile recommend:

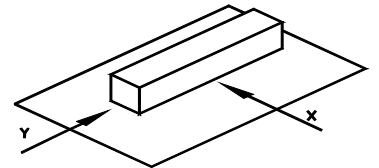

Lead-free heat endurance test

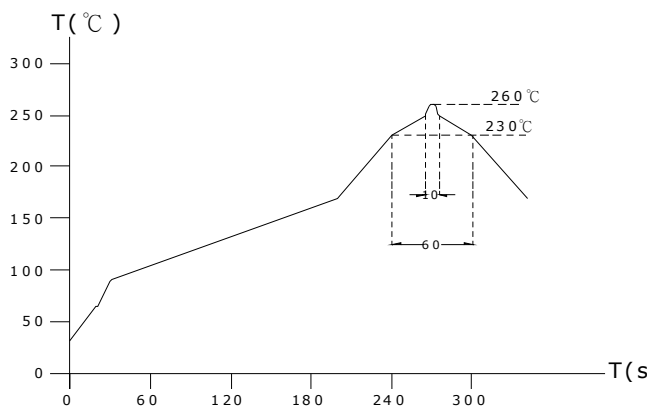

Lead-free the recommended reflow condition

