

● FEATURE

1. High current capacity and Low DCR(used ceramic base)
2. High heat resistance, ideal for reflow soldering

● Applications

1. DC-DC converter
2. Set top box and Notebook and Server, etc

● Shape and Dimension

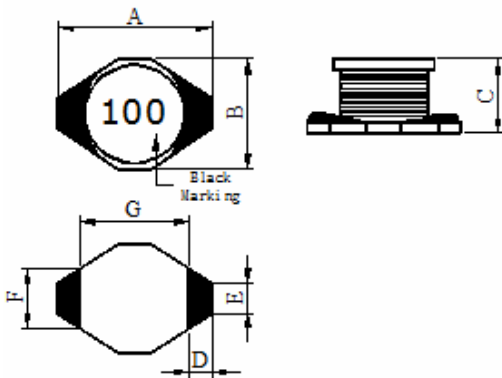

● Schematics and Land Patterns(mm)

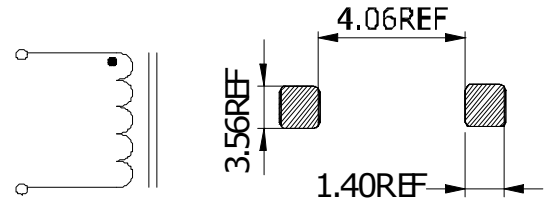

A=6.60 m/m MAX; B=4.45 m/m MAX ; C=2.92 m/m MAX ; D=1.02 m/m REF; E=1.27 m/m REF
F=3.05 m/m REF ; G=4.32 m/m REF (Black Marking: Inductance value)

● Specification

P/N	L (μ H)	Marking	SRF (MHz) typ	RDC (Ω)Max	Isat (A)	Irms (A)
EPO1608-1R0M	1.0 \pm 20%	1R0	130	0.05	2.9	2.9
EPO1608-1R5M	1.5 \pm 20%	1R5	115	0.06	2.6	2.8
EPO1608-2R2M	2.2 \pm 20%	2R2	100	0.07	2.3	2.4
EPO1608-2R7M	2.7 \pm 20%	2R7	75	0.08	2.1	2.1
EPO1608-3R3M	3.3 \pm 20%	3R3	70	0.08	2.0	2.0
EPO1608-4R7M	4.7 \pm 20%	4R7	50	0.09	1.5	1.5
EPO1608-6R8M	6.8 \pm 20%	6R8	45	0.13	1.2	1.4
EPO1608-8R2M	8.2 \pm 20%	8R2	40	0.16	1.15	1.3
EPO1608-100M	10 \pm 20%	100	35	0.16	1.1	1.2
EPO1608-150M	15 \pm 20%	150	30	0.23	0.9	1.1
EPO1608-220M	22 \pm 20%	220	20	0.37	0.70	0.80
EPO1608-330M	33 \pm 20%	330	15	0.51	0.58	0.60
EPO1608-470M	47 \pm 20%	470	14	0.64	0.50	0.50
EPO1608-680M	68 \pm 20%	680	11	0.86	0.40	0.40

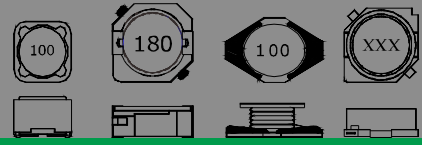
**SMD POWER INDUCTOR
– EPO1608 SERIES**

P/N	L (μ H)	Marking	SRF (MHz) typ	RDC (Ω)Max	Isat (A)	Irms (A)
EPO1608-101M	100 \pm 20%	101	9	1.27	0.31	0.30
EPO1608-151M	150 \pm 20%	151	6	2.00	0.27	0.25
EPO1608-221M	220 \pm 20%	221	5.5	3.11	0.22	0.20
EPO1608-331M	330 \pm 20%	331	5	3.80	0.18	0.16
EPO1608-471M	470 \pm 20%	471	4	5.06	0.16	0.15
EPO1608-681M	680 \pm 20%	681	3	9.20	0.14	0.12
EPO1608-102M	1000 \pm 20%	102	2	13.8	0.10	0.07

Note1. Measurement frequency of Inductance value : at 100KHz, 0.1V

Note2. Measurement ambient temperature of L, DCR and IDC : at 25°C

Note3. Isat: DC current at which the inductance drops 10%(typ) from its value without current

Note4. Irms: Average current for 40°C temperature rise from 25°C ambient

Note5. Inductance tolerance: M: \pm 20%

Note5.Packaging: Taping ; Quantity: 2500 Pieces/reel

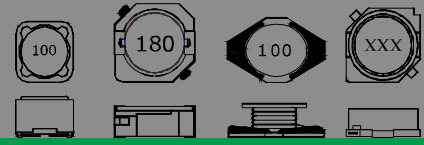

GENERAL CHARACTERISTICS

1. Operating temperature range: -40 TO + 105°C (Includes temperature when the coil is heated)
2. External appearance: On visual inspection, the coil has no external defects.
3. Terminal strength: After soldering. Between copper plate and terminals of coil. Push in two directions of X.Y withstanding at below conditions.

Terminal should not peel off. (refer to figure at right) 5. 0N 60 sec.

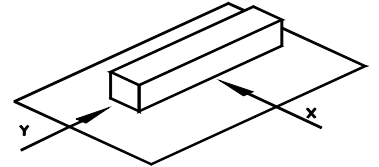

4. Insulating resistance: Over 100MΩ at 100V D.C. between coil and core.
5. Dielectric strength: No dielectric breakdown at 100V D.C. for 1 minute between coil and core.
6. Temperature characteristics: Inductance coefficient $(0\sim 2,000)\times 10^{-6}/^{\circ}\text{C}$ (-25~+80°C).
7. Humidity characteristics(Moisture Resistance): Inductance deviation within $\pm 5\%$, after 96 hours in 90~95% relative humidity at $40 \pm 2^{\circ}\text{C}$ and 1 hour drying under normal condition.
8. Vibration resistance: Inductance deviation within $\pm 5\%$, after vibration for 1 hour. In each of three orientations at sweep vibration (10~55~10 Hz) with 1.5mm P-P amplitudes.
9. Shock resistance: Inductance deviation within $\pm 5\%$, after being dropped once with 981m/s² (100G) shock attitude upon a rubber block method shock testing machine, in three different orientations.
10. Resistance to Soldering Heat: 260°C, 10 seconds(See attached recommend reflow)
11. Storage environment: Storage condition: Temperature Range: 10°C ~ 35°C (Generally: 21°C ~ 31°C) , Humidity Range: 50% ~ 80% RH (Generally: 65% ~ 75%) ; Transportation condition: Temperature Range: -35°C ~ 85°C , Humidity Range: 50% ~ 95% RH
12. Use components within 12 months. If 12 months or more have elapsed, check solderability before use.
13. Reflow profile recommend:

Lead-free heat endurance test

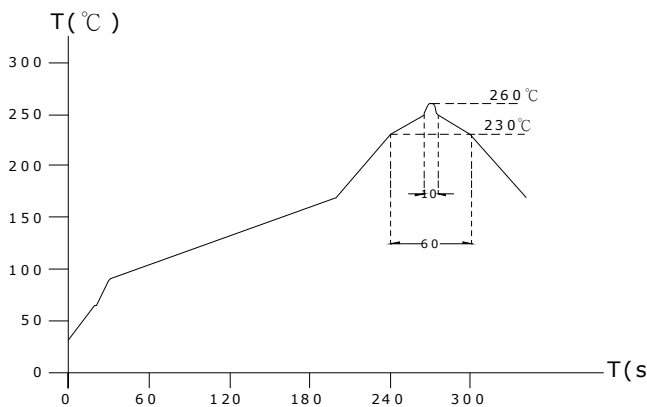

Lead-free the recommended reflow condition

