

# COMMON MODE INDUCTORS

## – EF4P1210D SERIES



### ●FEATURE

1. High common mode impedance at high frequency effects excel noise suppression performance
2. Suitable for differential signal line like HDMI 2.0, IEEE 1394 and LVDS

### ●Applications

1. Ideal for use as common-mode chokes for USB1.1/USB2.0/IEEE 1394 interface

### ●Shape and Dimension and Schematics and Land Patterns(mm)

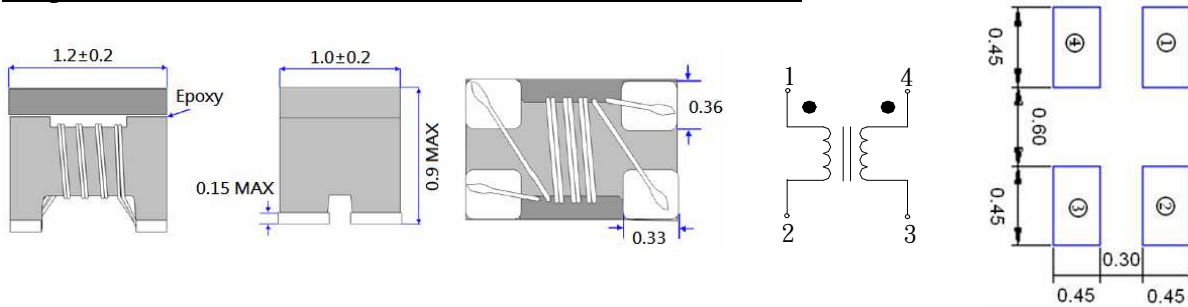

### ●Specification

PART NO.	Common Mode Impedance (ohm) ( tolerance±25%)	Rated Current (mA)	Rated Voltage (Vdc)	Insulation Resistance (M ohm)	DC Resistance (max.) (ohm)
EF4P1210D-150	15 (Typ.) at 100MHz	300	20	10 min	0.30
EF4P1210D-250	25 (Typ.) at 100MHz	300	20	10 min	0.30
EF4P1210D-400	40 (Typ.) at 100MHz	300	20	10 min	0.30
EF4P1210D-500	50 (Typ.) at 100MHz	300	20	10 min	0.40
EF4P1210D-900	90 (Typ.) at 100MHz	280	20	10 min	0.50
EF4P1210D-101	100 (Typ.) at 100MHz	270	20	10 min	0.55
EF4P1210D-121	120 (Typ.) at 100MHz	270	20	10 min	0.55

Note1. Measurement ambient temperature of electrical : at 20°C

Note2. Test equipment: HP4291A



## GENERAL CHARACTERISTICS

1. Operating temperature range: -40 TO + 105°C (Includes temperature when the coil is heated)
2. External appearance: On visual inspection, the coil has no external defects.
3. Terminal strength: After soldering. Between copper plate and terminals of coil. Push in two directions of X.Y withstanding at below conditions.  
Terminal should not peel off. (refer to figure at right) 0.5kg Min -EF4P1210D.
4. Insulating resistance: Over 100MΩ at 100V D.C. between coil and core.
5. Dielectric strength: No dielectric breakdown at 100V D.C. for 1 minute between coil and core.
6. Temperature characteristics: Inductance coefficient (0~2,000)x10-6/°C (-25~+80°C degree Celsius), inductance deviation within±5.0%, after 96 hours.
7. Humidity characteristics(Moisture Resistance): Inductance deviation within ±5%, after 96 hours in 90~95% relative humidity at 40 ±2°C and 1 hour drying under normal condition.
8. Vibration resistance: Inductance deviation within ±5%, after vibration for 1 hour. In each of three orientations at sweep vibration (10~55~10 Hz) with 1.5mm P-P amplitudes.
9. Shock resistance: Inductance deviation within ±5%, after being dropped once with 981m/s<sup>2</sup> (100G) shock attitude upon a rubber block method shock testing machine, in three different orientations.
10. Resistance to Soldering Heat: 260°C, 10 seconds(See attached recommend reflow)
11. Storage condition: Temperature Range: 0°C ~ 35°C ; -40°C ~ 85°C (after PCB) · Humidity Range: 60% RH
12. Use components within 12 months. If 12 months or more have elapsed, check solderability before use.
13. Reflow profile recommend:

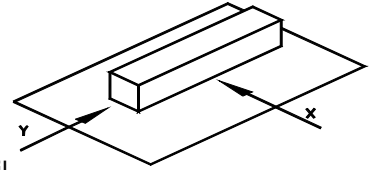

Lead-free heat endurance test

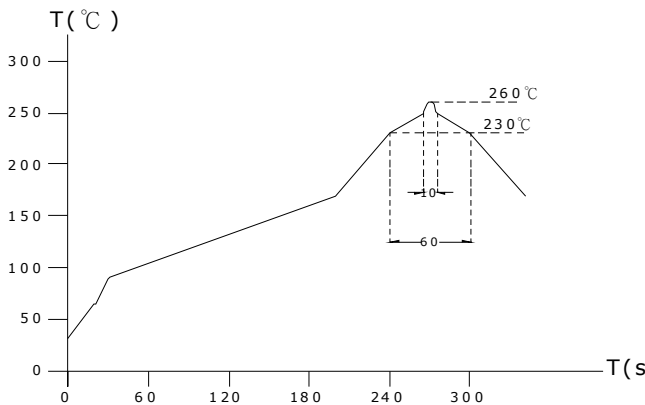

Lead-free the recommended reflow condition

