

COMMON MODE INDUCTORS – ECM9070FB SERIES

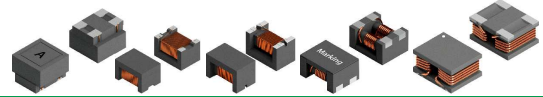

●FEATURE

1. Capable of handling the highest current(up to 5A) of any chip-type common mode filter
2. Noise is greatly suppressed.
3. Same as TDK ACM9070 series

●Applications

1. Used for power line noise suppression for any electric devices. Used to counter adapter/battery line noise for relatively large electronic devices such as notebook , stand-alone word processor, etc.

●Shape and Dimension

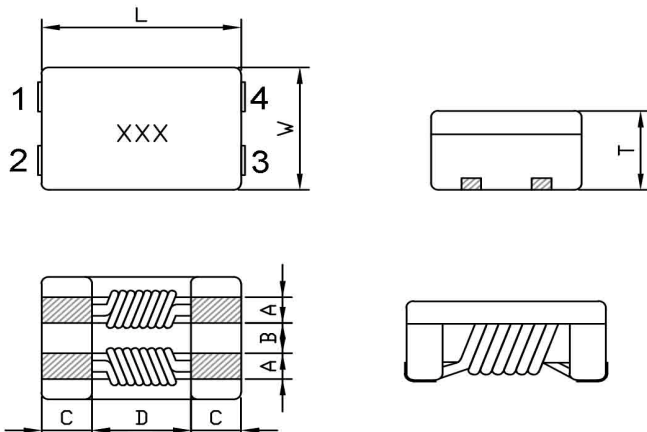

●Schematics and Land Patterns(mm)

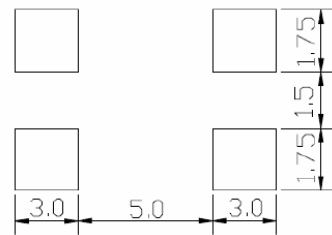
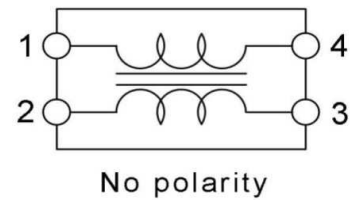

L=9.00±0.50 m/m ; W=7.00±0.50 m/m ; T=4.50 m/m Max ; A=1.50 m/m Ref. ; B=2.00 m/m Ref. C=1.70 m/m Ref. ; D=5.70 m/m Ref.; Black cover

●Specification

Part number	Common mode Impedance Z(Ω) at 100MHz		DC Resistance (mΩ Max)	Rated Current(A)	Rated Voltage(V)	Insulation Resistance (MΩ)Min
	min	typical				
ECM9070FB-301	225	300	6	6	80	10
ECM9070FB-501	350	500	8	6	80	10
ECM9070FB-701	500	700	10	5	80	10
ECM9070FB-102	750	1000	13	4	80	10
ECM9070FB-152	1300	1500	15	3	80	10

Note1. Measurement ambient temperature of Impedance, DCR and IDC : at 25°C

Note2. Packing: reel ; Quantity: 700pcs/reel

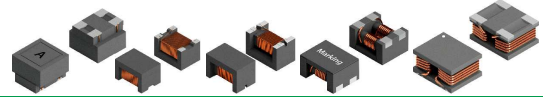

GENERAL CHARACTERISTICS

- Operating temperature range: -40 TO + 125°C (Includes temperature when the coil is heated)
- External appearance: On visual inspection, the coil has no external defects.
- Terminal strength: After soldering. Between copper plate and terminals of coil. Push in two directions of X.Y withstanding at below conditions.
Terminal should not peel off. (refer to figure at right) 5. 0N 60 sec.
- Insulating resistance: Over 100MΩ at 100V D.C. between coil and core.
- Dielectric strength: No dielectric breakdown at 100V D.C. for 1 minute between coil and core.
- Temperature characteristics: Inductance coefficient $(0\sim 2,000)\times 10^{-6}/^{\circ}\text{C}$ (-25~+80°C) , inductance deviation within $\pm 5.0\%$, after 96 hours
- Humidity characteristics(Moisture Resistance): Inductance deviation within $\pm 5\%$, after 96 hours in 90~95% relative humidity at $40 \pm 2^{\circ}\text{C}$ and 1 hour drying under normal condition.
- Vibration resistance: Inductance deviation within $\pm 5\%$, after vibration for 1 hour. In each of three orientations at sweep vibration (10~55~10 Hz) with 1.5mm P-P amplitudes.
- Shock resistance: Inductance deviation within $\pm 5\%$, after being dropped once with 981m/s² (100G) shock attitude upon a rubber block method shock testing machine, in three different orientations.
- Resistance to Soldering Heat: 260°C, 10 seconds(See attached recommend reflow)
- Storage environment: Storage condition: Temperature Range: 10°C ~ 35°C (Generally: 21°C ~ 31°C) , Humidity Range: 50% ~ 80% RH (Generally: 65% ~ 75%) ; Transportation condition: Temperature Range: -35°C ~ 85°C , Humidity Range: 50% ~ 95% RH
- Use components within 12 months. If 12 months or more have elapsed, check solderability before use.
- Reflow profile recommend:

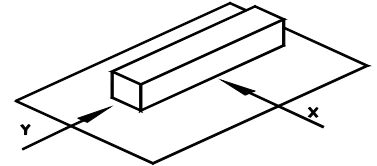

Lead-free heat endurance test

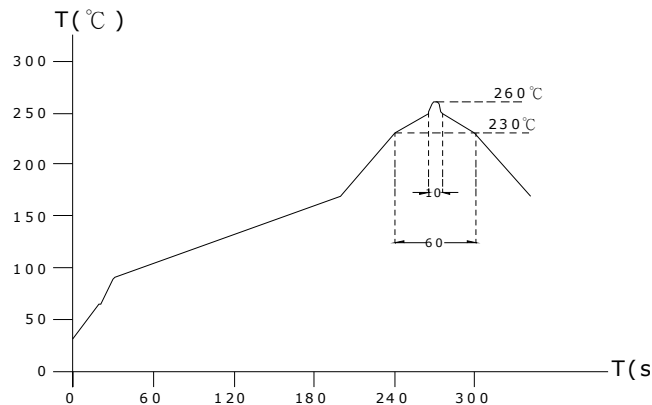

Lead-free the recommended reflow condition

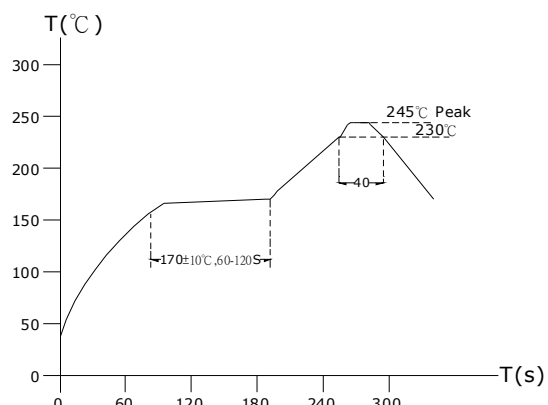

COMMON MODE INDUCTORS – ECM9070FB SERIES

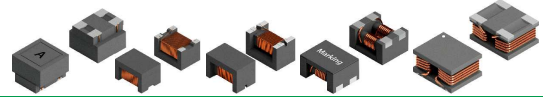

● Characteristics

ECM9070FB-301

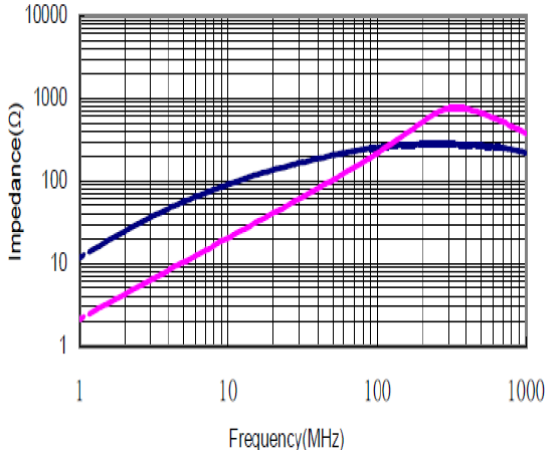

ECM9070FB-501

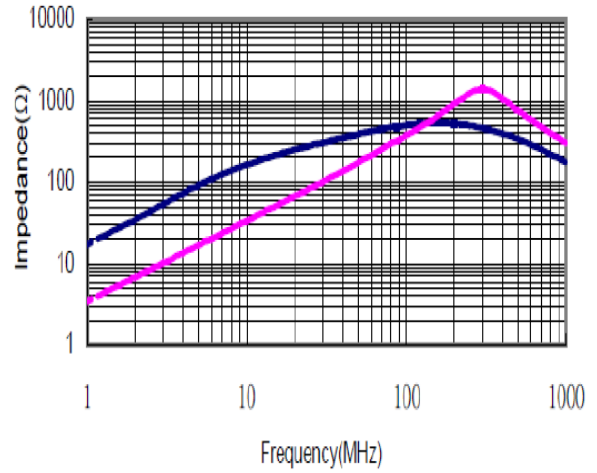

ECM9070FB-701

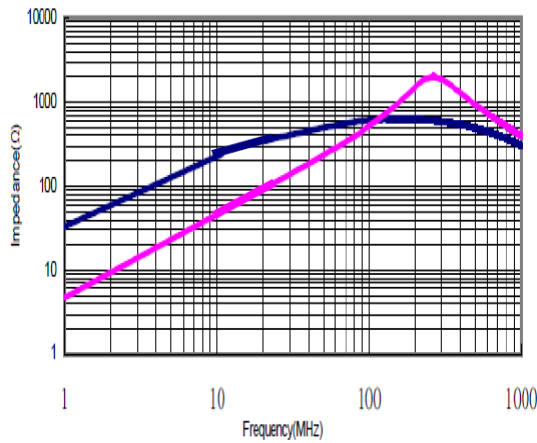

ECM9070FB-102

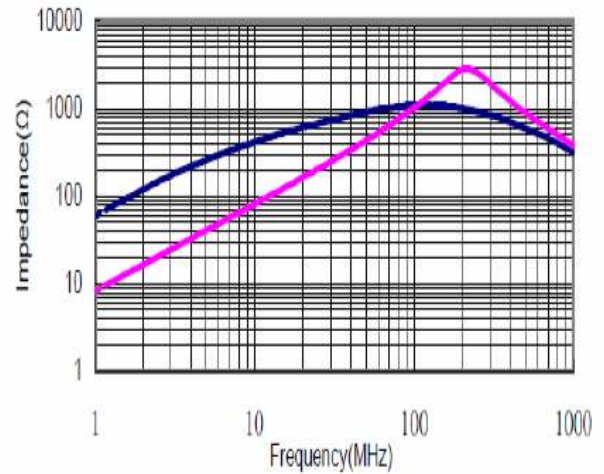

ECM9070FB-152

